

REVIEW ARTICLE THEMED ISSUE

Decorin-mediated oncosuppression – a potential future adjuvant therapy for human epithelial cancers

Correspondence Annele Orvokki Sainio, Institute of Biomedicine, Medical Biochemistry and Genetics, University of Turku, Kiinamylynkatu 10, 20520 Turku, Finland. E-mail: anorsa@utu.fi

Received 28 November 2017; **Revised** 22 January 2018; **Accepted** 29 January 2018

Annele Orvokki Sainio¹  and Hannu Tapio Järveläinen^{1,2}

¹*Institute of Biomedicine, Medical Biochemistry and Genetics, University of Turku, Kiinamylynkatu 10, 20520 Turku, Finland, and* ²*Department of Internal Medicine, Satakunta Central Hospital, Sairaalanatie 3, 28500 Pori, Finland*

Currently, the multifaceted role of the extracellular matrix (ECM) in tumourigenesis has been realized. One ECM macromolecule exhibiting potent oncosuppressive actions in tumourigenesis is decorin, the prototype of the small leucine-rich proteoglycan gene family. The actions of decorin include its ability to function as an endogenous pan-receptor tyrosine kinase inhibitor, a regulator of both autophagy and mitophagy, as well as a modulator of the immune system. In this review, we will discuss these topics in more detail. We also provide a summary of preclinical studies exploring the value of decorin-mediated oncosuppression, as a potential future adjuvant therapy for epithelial cancers.

Abbreviations

Ad, adenoviral; ECM, extracellular matrix; EGFR/ErbB1, EGF receptor 1; GAG, glycosaminoglycan; IGF-IR, insulin-like growth factor receptor 1; LRR(s), leucine-rich repeat(s); Met, receptor for hepatocyte growth factor; p21^{WAF-1}, cyclin-dependent kinase inhibitor 1; p27^{Kip-1}, cyclin-dependent kinase inhibitor 1B; PDGF(R- α/β), PDGF (receptor α/β); Peg3, paternally expressed gene 3; (Pan-) RTK(s), (Pan-) receptor tyrosine kinase(s); SFDA, State Food and Drug Administration

Introduction

The main function of the extracellular matrix (ECM) is to maintain normal architecture and homeostasis in a tissue-specific manner. During tumour development, the ECM becomes dysregulated and can therefore provide a favourable micro-environment during all the stages of tumourigenesis (Schaefer *et al.*, 2017). One of the crucial modulators of ECM structure and function is decorin, an archetypal member of the small leucine-rich proteoglycan gene family (Gubbiotti *et al.*, 2016).

Recently, several studies focusing on decorin in tumourigenesis have, together, indicated that decorin is a potent oncosuppressive molecule (Neill *et al.*, 2015b; Theocharis and Karamanos, 2017; Schaefer *et al.*, 2017). Originally, this was observed when mice lacking both decorin and p53 were shown to exhibit a faster rate of tumour growth than p53 null animals, suggesting that the lack of decorin was tumour-permissive (Iozzo *et al.*, 1999). Today, we know that in different malignancies such as breast cancer, bladder cancer and colon cancer, the expression of decorin is markedly decreased (Theocharis and Karamanos, 2017), so that the malignant cells of these carcinomas do not express decorin (Boström *et al.*, 2013; Sainio *et al.*, 2013; Nyman *et al.*, 2015). On the other hand, the delivery of decorin or the induction of its expression in carcinoma cells has been shown to attenuate the malignant behaviour of cells through a variety of mechanisms (Bi and Yang, 2013; Neill *et al.*, 2016; Boström *et al.*, 2017). Because decorin is an extracellular proteoglycan and its regulatory function is mediated *via* paracrine action, it can transmit a distant oncosuppressive effect on cancer cells (Tralhão *et al.*, 2003).

As such, decorin-based adjuvant therapies provide a potential option for treatment of various carcinomas in the future. In this review, we will introduce the structural and

functional properties of decorin in more detail. We will particularly focus on decorin as an oncosuppressive molecule and summarize its regulatory activity on different cellular functions including autophagy, mitophagy and immunity. We will also discuss representative preclinical studies utilizing decorin-based therapies in the treatment of cancers, especially epithelial cancers.

Decorin – structure, interactions and functions

Molecular structure of decorin

Decorin, originally called PG-II, PG-40 and PG-S2, is the prototypic member of the small leucine-rich proteoglycan gene family. The name decorin is derived from an early finding that decorin can bind to, that is, ‘decorate’ collagen type I fibres. Decorin is composed of an approximately 40 kDa core protein to which is attached one glycosaminoglycan (GAG) side chain and up to three N-linked oligosaccharides (Figure 1). The single unbranched GAG side chain of decorin is either chondroitin sulfate or dermatan sulfate, and it is attached to Ser⁴ in the second domain of the core protein. The GAG of decorin is a heterogenic polymer consisting of chondroitin and/or dermatan sulfate in variable amounts, depending on the tissue type (Seidler and Dreier, 2008). In chondroitin sulfate, the uronic acid of the repeating disaccharide is D-glucuronic acid, which in dermatan sulfate is epimerized to L-iduronic acid. The third domain contains the leucine-rich repeats (LRRs) typical of the small leucine-rich proteoglycans such as decorin. This domain gives decorin its arch-like three-dimensional structure. The second and the fourth domains of the decorin core protein are rich in cysteine residues with two disulfide bridges on the N-terminal side and one on the C-terminal side.

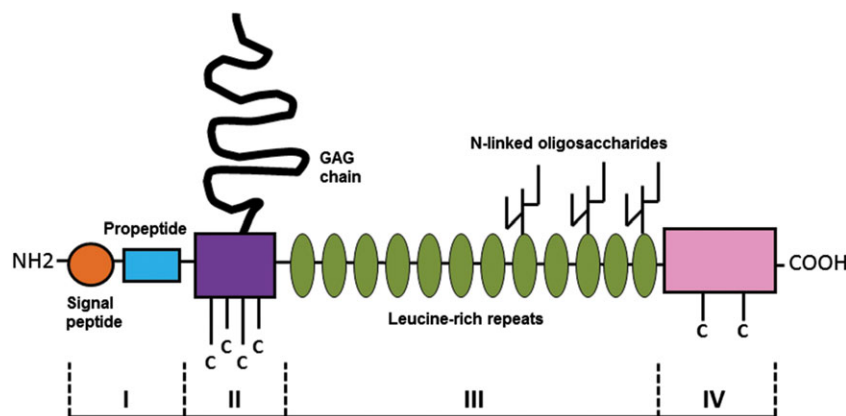

Figure 1

Schematic structure of decorin. The decorin core protein comprises four domains, shown as I–IV. Domain I is the signal peptide and the propeptide-containing domain which is cleaved before decorin can be secreted into the ECM. Domain II (rich in cysteine residues) is the domain where the single GAG side-chain (either chondroitin sulfate or dermatan sulfate) is attached to Ser⁴. Domain III (characteristic of decorin) consists of 12 tandem LRRs and up to three N-linked oligosaccharides. Similar to domain II, the carboxy terminal domain (domain IV) contains two cysteine residues. There are two disulfide bridges on the N-terminal side, and one on the C-terminal side (not shown in figure). Both the LRR domain (domain III) and the single GAG side chain are primarily responsible for decorin’s multiple interactions with other molecules, the LRR domain being crucial for decorin-protein interactions. C, cysteine residue.

Interactions and functions of decorin as a whole molecule

Both the core protein of decorin, especially the LRR domain, and the GAG side chain enable decorin to bind and sequester a large number of different molecules. These decorin-interacting partners encompass versatile molecular categories including ECM macromolecules, growth factors and some of their receptors, cytokines, enzymes, hormones and lipoproteins (Figure 2) (Yamaguchi *et al.*, 1990; Bi and Yang, 2013; Gubbiotti *et al.*, 2016; Torres *et al.*, 2017). These interactions form the basis of decorin's multifaceted functions.

Originally, decorin was shown to be involved in collagen fibrillogenesis in corneal stroma, where its presence inhibited fibrillogenesis (Danielson *et al.*, 1997). Thereafter, decorin and collagen interaction was shown to be crucial for both proper fibril formation and fibril spacing, as discussed above (Danielson *et al.*, 1997). Moreover, decorin was identified to induce negative feedback regulation on cell growth *via* its capability to bind to and interact with **TGF- β** (Yamaguchi *et al.*, 1990). Interestingly, this interaction with TGF- β was shown to occur when decorin was bound to collagen. Currently, decorin is known for its multifunctional activities crucially involved in key cellular events, including regulation of cell signalling, migration, proliferation and apoptosis (Neill *et al.*, 2015b; Gubbiotti *et al.*, 2016). These topics will be

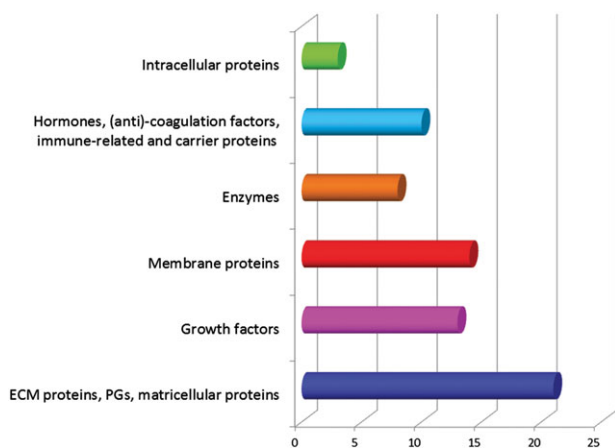

Figure 2

Various molecular categories of decorin's interactions. The groups are modified from the analysis performed by Gubbiotti *et al.* (2016), where they identified decorin-binding ligands in the literature and in different interaction databases including MatrixDB (<http://matrixdb.univ-lyon1.fr/>). Representative examples of proteins in each different category are as follows: intracellular proteins (filamin A, tyrosine 3-monooxygenase and zinc finger, and BTB domain containing 33); hormones, (anti)-coagulation factors, immune-related and carrier proteins (insulin, tissue-type plasminogen activator, von Willebrand factor and LDL); enzymes (matrix metalloproteinase 2, 3 and 7); membrane proteins (EGF receptors 1, 2 and 4; IGF-IR; hepatocyte growth factor receptor; and TLRs 2 and 4); growth factors (TGF β -1 and -2, and FGF-1, -2, -7 and -8); and ECM proteins, PGs and matricellular proteins (collagens I–VI, perlecan, fibronectin and thrombospondin 1). The X-axis indicates the number of molecules (n) in each category. For more details of the various categories, see the reference above. PGs, proteoglycans.

presented in more detail in the later sections in association with oncogenesis.

Decorin is also involved in several physiological processes such as gonad and chondrogenic differentiation, and angiogenesis (Järveläinen *et al.*, 2015; Gubbiotti *et al.*, 2016). For example, together with collagen type VI, decorin has a profound positive effect on the pericellular composition and biomechanical behaviour of human mesenchymal stem cells undergoing chondrogenesis (Gubbiotti *et al.*, 2016). In angiogenesis, the effect of decorin is context-dependent, excluding tumourigenesis where decorin acts as an anti-oncogenic molecule (Järveläinen *et al.*, 2015). Furthermore, evidence exists that it has a regulatory role in postpartum cell differentiation, including myotube (El Shafey *et al.*, 2016) and nephron progenitor cell differentiation (Fetting *et al.*, 2014) as well as spermatogenesis (Adam *et al.*, 2012). In myogenesis, decorin activates the differentiation of myogenic cells into skeletal muscle cells *via* binding and inactivating the mature myostatin in a zinc-dependent manner (El Shafey *et al.*, 2016). Myostatin is a member of the TGF- β superfamily, and it is involved in the regulation of skeletal muscle mass. On the other hand, during kidney development, decorin is able to promote the retention of nephron progenitor cells in an undifferentiated state (Fetting *et al.*, 2014). Also in spermatogenesis, decorin acts as a negative regulator of testicular function (Adam *et al.*, 2012). In fact, the testis of a mouse model with inflammation-associated infertility, as well as testis of infertile men, exhibit significantly increased levels of decorin expression. Subsequently, this increase in the amount of decorin was associated with increased number of **TNF- α** – producing immune cells (Adam *et al.*, 2012). Regarding intestinal homeostasis, it was shown that decorin expression is vital for the maintenance of cell maturation (Bi *et al.*, 2008). During tumourigenesis, decorin was further shown to be a regulator of the innate immune system (Merline *et al.*, 2011; Frey *et al.*, 2013), autophagy (Torres *et al.*, 2017) and mitophagy (Buraschi *et al.*, 2017), as discussed in more detail below. Although most of decorin's interactions are mediated *via* its core protein, the GAG side chain is also of great importance (Järvinen and Prince, 2015; Neill *et al.*, 2016).

Interactions and functions of the decorin GAG side chain

The GAG side chain has a central function during collagen fibrillogenesis, where it controls the distance between the forming collagen fibrils (Danielson *et al.*, 1997). This means that if the length of the GAG is reduced, it decreases the distance between collagen fibrils. Regarding binding of decorin to collagen type I in human dermis, age-related modifications in the GAG can be observed (Li *et al.*, 2013). Thus, the molecular size of decorin GAG and the amount of total sulfated GAGs are reduced by 40% in aged human skin compared to young skin without any decrease in the amount of decorin core protein (Li *et al.*, 2013). This may contribute to the skin fragility of elderly people (Danielson *et al.*, 1997; Li *et al.*, 2013). Interestingly, for example, in a specific progeroid phenotype of Ehlers-Danlos syndrome, 30–70% of decorin molecules are produced without GAG chains (Seidler and Dreier, 2008). Furthermore, the GAG and collagen type I interaction

is also essential for the retention of LDL particles in collagen-rich areas of atherosclerotic plaques (Tannock, 2014). In other words, decorin has been identified as one of the vascular proteoglycans participating in the 'response to retention' hypothesis of atherosclerosis. This hypothesis provides an established explanation for the initiation of atherosclerosis where vascular proteoglycans interact with apolipoprotein B-containing lipoproteins resulting in their retention in the vascular wall. As a result, this LDL-proteoglycan interaction has been proposed to represent a novel therapeutic target, particularly in the initiation phase of atherosclerosis (Tannock, 2014).

Regarding tumourigenesis, the structure of decorin GAG chain may vary depending on the pathological condition. For example, in human colon adenocarcinoma (Theocharis, 2002) and in gastric carcinoma (Theocharis *et al.*, 2003), the GAGs are mostly chondroitin sulfate. Additionally, the GAG of decorin can exhibit a variety of post-translational modifications in cancer (Theocharis, 2002; Theocharis *et al.*, 2003; Seidler and Dreier, 2008). In gastric cancer, the GAG contains markedly increased amounts of non-sulfated and 6-sulfated disaccharide units compared to normal gastric mucosa (Theocharis *et al.*, 2003). Identical results have been reported in pancreatic cancer (Skandalis *et al.*, 2006). Although decorin core protein is the primary structure in the sequestering of various growth factors, a GAG rich in chondroitin sulfate with specific sulfation patterns can interact with, for example, **fibroblast growth factor 2** (Theocharis and Karamanos, 2017). Subsequently, this leads to the activation of the **MAPK** pathway and to malignant transformation (Theocharis and Karamanos, 2017). Thus, the post-translational sulfation patterns act as a critical molecular recognition elements for different growth factors enabling tumour progression.

Decorin and oncosuppression

Cancer cells are known to create their own micro-environment which provides tumourigenesis-promoting surroundings (Neill *et al.*, 2015b). This is accomplished *via* reciprocal interactions between the cancer cells and the surrounding non-malignant stromal cells such as normal fibroblasts, activated fibroblasts (myofibroblasts), cancer-associated fibroblasts, inflammatory cells and various ECM macromolecules. Epithelial cancers (carcinomas) represent the major group of all human cancers. Indeed, the progression of cancer is known to be dependent on the complex interactions between cancer cells and their adjacent stromal cells (Theocharis and Karamanos, 2017). Regarding carcinomas, the malignant cells completely lack decorin expression (Boström *et al.*, 2013; Nyman *et al.*, 2015; Sainio *et al.*, 2013). However, decorin can be produced by the peritumoral stromal cells, for example, cancer-associated fibroblasts. Because decorin is a secreted ECM molecule, its regulatory function is mediated primarily *via* paracrine actions (Tralhão *et al.*, 2003; Buraschi *et al.*, 2012; Buraschi *et al.*, 2017).

Decorin as a pan-receptor tyrosine kinase inhibitor

An overview of the regulatory pathways and functions of decorin in cancer is presented in Figure 3. First of all, decorin

acts as a **pan-receptor tyrosine kinase** (pan-RTK) inhibitor (Neill *et al.*, 2016). Nearly 20 years ago, it was shown that decorin core protein is able to cause generalized growth suppression of neoplastic cells of various histogenic origin *via* up-regulating p21^{WAF-1}, a potent inhibitor of **cyclin-dependent kinases**, subsequently inducing G1 cell cycle arrest (Santra *et al.*, 1997). The cell cycle arrest was further coupled with apoptosis, which resulted from the cleavage and subsequent activation of **caspase-3** after decorin treatment (Neill *et al.*, 2015b). This mechanism is of particular importance for inhibition of growth and angiogenesis of cancers enriched with EGF receptors (**EGFR/ErbB1**), receptors for hepatocyte growth factor (**Met**) and **VEGF receptor 2** (Neill *et al.*, 2015a; Neill *et al.*, 2016). Decorin was also shown to be able to inhibit the activity of **ErbB2** by regulating the amount of active EGRF/ErbB2 dimers (Neill *et al.*, 2015b). In the CNS, decorin binds directly to and thereby suppresses the activity of **ErbB4**/signal transducer and activator of transcription protein 3 signalling (Minor *et al.*, 2011). In addition, decorin has the ability to inhibit various other RTKs, including insulin-like growth factor receptor 1 (**IGF-IR**) and **PDGF** receptor α/β (Neill *et al.*, 2015b; Neill *et al.*, 2016).

Mechanistically, decorin as a monomer operates in the tumour stroma by binding different receptor tyrosine kinases, activating their dimerization and inducing transient autophosphorylation (Theocharis and Karamanos, 2017). This leads to caveolin-1-mediated endocytosis of the activated receptor complex and finally to its lysosomal degradation (Neill *et al.*, 2015b). Interestingly, IGF-IR seems to represent the only example among the tumour-associated RTKs, whose binding with decorin does not lead to internalization and destruction of the receptor complex (Morrión *et al.*, 2013). Instead, decorin binding blocks the activation of IGF-IR and suppresses its downstream signalling, thus inhibiting cancer cell motility, invasion and proliferation in a context-dependent manner (Morrión *et al.*, 2013). Among RTKs, IGF-IR is known to be an essential mediator of the progression and cellular proliferation of different human cancers, including breast cancer. The action of decorin in transformed cells is very intriguing, because in normal cells, decorin binding to IGF-IR induces its phosphorylation leading to downstream signalling activation and ultimately receptor degradation (Morrión *et al.*, 2013; Neill *et al.*, 2015a). The crosstalk between EGFR and IGF-IR in oestrogen-responsive breast cancers is also currently emerging, highlighting the essential role and production of the ECM molecules in the regulation of cancer aggressiveness (Afratis *et al.*, 2017). Specifically, it appears that the interaction between the **oestradiol receptor** and EGFR/IGF-IR modulates the expression and localization of various matrix molecules, particularly proteoglycans (Afratis *et al.*, 2017).

Decorin in autophagy and mitophagy

Autophagy has traditionally been regarded as a tumour-promoting process, allowing prolonged survival for the cancer cells. Nonetheless, it has been shown that at certain stages of tumourigenesis, autophagy can in fact inhibit the progression of tumour growth by protecting the primary stromal cells from cancer-associated metabolic stress induced by cellular debris and protein aggregates (Goyal *et al.*, 2014). In a

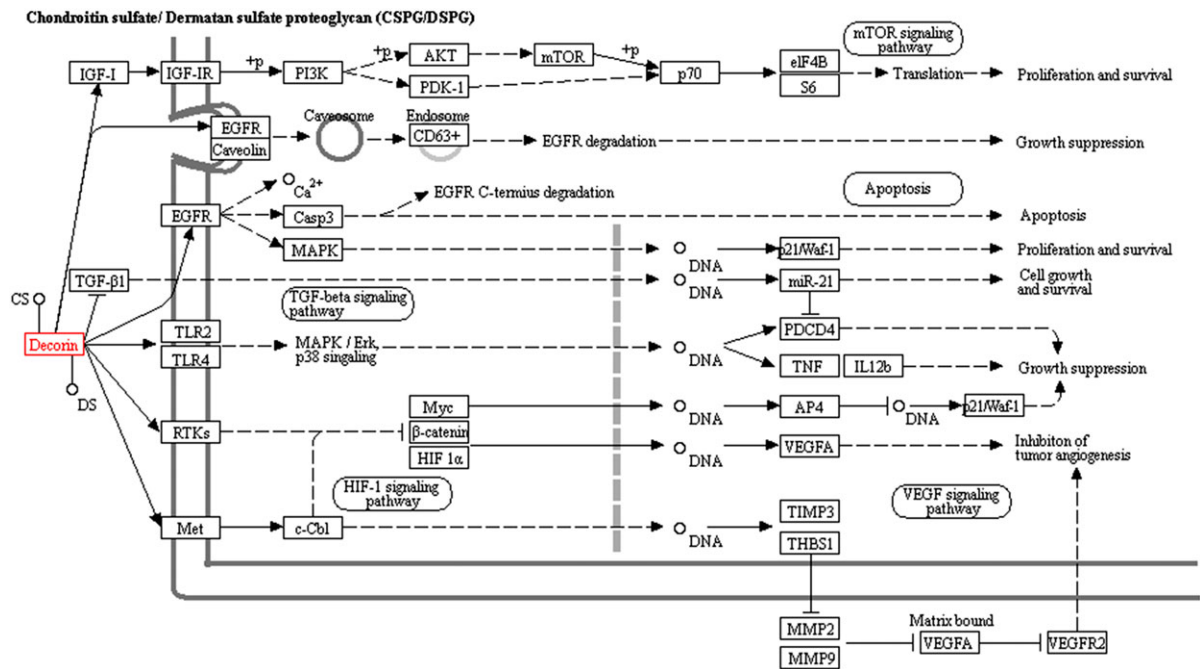

Figure 3

Decorin in cancer, based on the Kyoto Encyclopedia of Genes and Genomes (KEGG) database (http://www.genome.jp/kegg-bin/show_pathway?hsa05205). This pathway map presents representative examples of decorin interactions with various growth factors and their receptors and subsequent signalling pathways. The Figure is published with permission of the copyright holder (Kanehisa *et al.*, 2017). Decorin has one GAG side chain which can be either chondroitin sulfate (CS) or dermatan sulfate (DS), and both of these possibilities are presented in the figure. Additional abbreviations used in the figure are as follows: AP4, activating enhancer binding protein 4; Casp3, caspase 3; c-Cbl, E3 ubiquitin-protein ligase; eIF4B, eukaryotic translation initiation factor 4B; HIF 1 α , hypoxia-inducible factor 1- α ; miR-21, micro-RNA 21; mTOR, mechanistic target of rapamycin; Myc, Myc proto-oncogene protein; PDCD4, programmed cell death 4; PDK-1, pyruvate dehydrogenase kinase 1; S6, S6 kinase; THBS1, thrombospondin 1; TIMP3, tissue inhibitor of metalloproteinase 3.

preclinical transcriptomic screening using a triple-negative orthotopic breast carcinoma model, systemic administration of decorin core protein altered the global gene expression profile of the tumour micro-environment (Buraschi *et al.*, 2012). Decorin was also able to reprogramme the tumour stroma in a paracrine fashion, turning it into a less favourable environment for the progression of cancer (Buraschi *et al.*, 2012). This effect has been linked with the evoked expression of paternally expressed gene 3 (Peg3), an imprinted tumour suppressor gene, which is directly involved in the regulation of endothelial cell autophagy (Torres *et al.*, 2017). Also a more precise signalling cascade has been revealed in endothelial cells, where decorin, along with other molecules, inhibited anti-autophagic signalling by suppressing Akt/mTOR/p706K activity, simultaneously activating AMPK-mediated pro-autophagic signalling pathways (Goyal *et al.*, 2014). Currently, decorin-inducible Peg3 has been shown to attenuate angiogenesis *via* thrombospondin 1 expression, which occurs independently of signalling pathways leading to autophagy (Torres *et al.*, 2017). In addition to acting as an endogenous inhibitor of angiogenesis, thrombospondin 1 is known to variously affect the behaviour of cancer cells including their proliferation, invasion and apoptosis (Torres *et al.*, 2017).

Mitochondrial autophagy, a process called mitophagy, sequesters and specifically degrades dysfunctional mitochondria before they can cause apoptosis. Interestingly, soluble decorin protein core is able to induce tumour cell mitophagy

via binding to the Met receptor and thereby inducing mitostatin production (Neill *et al.*, 2015b; Buraschi *et al.*, 2017; Schaefer *et al.*, 2017). The increased amount of mitostatin was further demonstrated to parallel the increased production of **PPAR γ coactivator-1 α** , and this interaction was shown to lead to stabilized mitostatin mRNA and subsequent accrual of mitostatin protein (Buraschi *et al.*, 2017). Similar to Peg3, mitostatin was identified as a tumour suppressor gene (Torres *et al.*, 2017). Furthermore, the decorin-induced mitostatin-dependent mitophagy was linked with negative feedback control of **VEGFA** and consequently with the inhibition of tumour angiogenesis (Buraschi *et al.*, 2017).

Decorin as a modulator of the immune system

The role of decorin associated with inflammation seems to be versatile and significantly context-dependent. In normal macrophages, decorin controlled their proliferation by inducing arrest in the G1 phase of cell cycle (Xaus *et al.*, 2001). This is achieved by inducing the expression of cyclin-dependent kinase inhibitors p21^{Waf-1} and p27^{Kip-1}, without any interaction with EGF receptors (Xaus *et al.*, 2001). Also in inflammatory and fibrotic kidney diseases, decorin suppressed inflammation through its binding and neutralizing of the activity of the pro-fibrotic factor TGF- β (Nastase *et al.*, 2017). Furthermore, decorin interaction with EGFRs and IGF-IRs was demonstrated to play a beneficial role in the pathogenesis of kidney diseases (Nastase *et al.*, 2017).

Contrasting effect was observed in chronic pancreatitis, where decorin is highly expressed in the stroma by activated pancreatic stellate cells (Königer *et al.*, 2006). The increased production of decorin was shown to induce the expression of the chemokine **CCL2**, a pro-inflammatory cytokine in macrophages. As a result, decorin was suggested to link together the extensive desmoplastic reactions and the sustained inflammation present in chronic pancreatitis (Königer *et al.*, 2006). In desmoplasia, the tumour mass becomes surrounded by a dense fibrotic tissue rich in ECM macromolecules such as collagen, proteoglycans and hyaluronan. It is typically detected in different cancers, particularly in pancreatic cancer, where it can considerably hinder the targeting of therapeutic drugs to cancer cells (Li *et al.*, 2018).

The association of inflammation with cancer is still unclear. However, inflammation is considered as an enabling feature of tumourigenesis, for example, in breast cancer (Merline *et al.*, 2011). Regarding immune responses in tumourigenesis, decorin can regulate two separate molecular interactions. First, decorin binds and inactivates TGF- β , thus attenuating its tumourigenesis promoting effect (Frey *et al.*, 2013). Without decorin, TGF- β would be able to up-regulate the levels of precursor and mature microRNA-21 (miR-21), a pro-tumorigenic molecule, which is up-regulated in various cancer cells (Merline *et al.*, 2011). Secondly, decorin can act as an endogenous ligand for toll-like receptors (**TLRs**) 2 and 4 on macrophages (Merline *et al.*, 2011). This interaction leads to the activation of pathways involving **p38**, MAPK and NF- κ B and subsequently increases the synthesis of known pro-inflammatory cytokines **IL-2** and TNF- α (Merline *et al.*, 2011; Frey *et al.*, 2013). Furthermore, decorin binding to TLR2/4 stimulates the production of programmed cell death 4, a translational repressor of various proteins including the anti-inflammatory cytokine **IL-10** in macrophages (Merline *et al.*, 2011). This cytokine represents one of the most important immunomodulatory cytokines whose signalling pathways connect inflammation and cancer. Thus, by decreasing the production of IL-10, decorin drives the cytokine profile towards a more pro-inflammatory phenotype and concomitantly suppresses tumour growth (Merline *et al.*, 2011).

Therapeutic implications of decorin

Previously, decorin has been reported to possess both synergistic and antagonistic biological interactions with current chemotherapies, such as **carboplatin** in ovarian cancer (Nash *et al.*, 1999) and carboplatin and **gemcitabine** in pancreatic cancer (Königer *et al.*, 2004) respectively. Nevertheless, as described above, the established role of decorin as a potent oncosuppressive molecule offers a great potential for decorin-based adjuvant therapies for epithelial cancers. So far, the therapeutic properties of decorin have been tested *in vitro* and *in vivo* using various delivery systems targeting different cancer cell types (Neill *et al.*, 2016). The preclinical study settings range from ectopic delivery of decorin core protein to adenoviral (Ad) and oncolytic decorin transduction of cancer cells, and the oncosuppression primarily targets tumour growth and progression. Representative preclinical studies based on the use of decorin in epithelial cancers are shown in Table 1.

According to the clinicaltrials.gov database (<https://clinicaltrials.gov/>), there are currently no clinical trials

testing decorin in the treatment of cancer. However, a pilot study using intravitreal injection of decorin in the prevention of proliferative vitreoretinopathy in perforating injuries (NCT02865031) ended in August 2016. However, the results of the study have still not been released. Furthermore, trials using adenoviral vectors and recombinant proteins in various cancers are ongoing, for example, in non-small cell lung cancer testing the effect of recombinant DNA-pVAX/L523S (NCT00062907). Overall, modified adenoviruses are the most used viral vectors in clinical trials. They possess several advantages for their use including efficient delivery to both non-dividing and dividing cells. According to the Gene Therapy Clinical Trials Worldwide (<http://www.abedia.com/wiley/vectors.php>), which is provided by the Journal of Gene Medicine, 20% of all clinical trials using non-integrating viral or non-viral vectors involved adenoviruses. The first adenoviral therapy against cancer, Gendicine, was approved for the treatment of head and neck squamous cell carcinoma in the year 2003 in China by the State Food and Drug Administration (SFDA). The gene therapy product is an adenovirus vector carrying the p53 tumour-suppressor gene. Thereafter, in 2005, the SFDA of China approved Oncorine, for advanced head and neck squamous cell carcinoma, and in October 2015, the US FDA approved Imlygic, for the treatment of melanoma in patients with inoperable tumours. Thus, the development of adenovirus-based therapies is justified.

Preclinical studies using decorin

As mentioned above, TGF- β is the first growth factor that was shown to be sequestered and its activity inhibited by decorin (Yamaguchi *et al.*, 1990). Just recently, transduction of pancreatic cancer cells with oncolytic adenoviral decorin vector was shown to suppress the expression of TGF- β resulting in suppression of growth of cancer cells and induction of their apoptosis (Li *et al.*, 2018). Additionally, decorin inhibited the expression and accumulation of ECM macromolecules such as collagen types I and III, elastin and **fibronectin**, thus attenuating the desmoplastic reaction surrounding pancreatic cancer cells (Li *et al.*, 2018). This was demonstrated in both orthotopic pancreatic tumours as well as in pancreatic cancer patient-derived tumour spheroids (Li *et al.*, 2018). The use of 3D tumour spheroids provide an approach that mimics the tumour micro-environment of the cancer including its ECM macromolecules and the cellular heterogeneity, more closely than animal models. Regarding breast carcinomas, both systemic delivery of decorin protein core (Goldoni *et al.*, 2008) and adenoviral transduction (Reed *et al.*, 2005) decreased the growth of the primary tumour and reduced the progression of metastasis, by inhibiting the ErbB2-mediated tyrosine kinase cascade and by decreasing the levels of ErbB2 respectively. ErbB2 has been implicated particularly in the progression of breast cancer including the invasion and metastasis of the cancer cells (Reed *et al.*, 2005). The study performed by Goldoni *et al.* (2008) also demonstrated that the effect of decorin on EGFR/ErbB signalling was more efficient than those evoked by an established, low MW, tyrosine kinase inhibitor, **AG879**. Thus, in their experimental setting, decorin prevented the metastatic spreading of cancer cells into lungs, whereas AG879 had no effect (Goldoni *et al.*, 2008). Adenoviral decorin transduction has also been shown to decrease bone metastasis of breast carcinoma *via* reduction

Table 1

Preclinical studies in cancers of epithelial origin. Unless otherwise indicated, cell lines are derived from human tumours

Tumour type	Cell line	Delivery system	Effect on tumour/ tumour cells	Reference
Carcinomas of various origin	HeLa, WiDr/HT-29, HCT-116, A431, PC3	Ectopic expression	Decreased growth	(Santra <i>et al.</i> , 1997)
Lung adenocarcinoma	A549	Ad-DCN	Tumour cell apoptosis and distant DCN anti-tumour effect	(Tralhão <i>et al.</i> , 2003)
Primary breast carcinoma and pulmonary metastasis	MTLn3 (rat)	Ad-DCN	Decreased primary growth and elimination of metastases	(Reed <i>et al.</i> , 2005)
Squamous cell carcinoma	A431	Systemic delivery of DCN protein core	Inhibition of tumour growth	(Seidler <i>et al.</i> , 2006)
Breast adenocarcinoma	MTLn3 (rat)	Systemic delivery of DCN protein core	Inhibition of primary tumour growth and reduction of metastasis	(Goldoni <i>et al.</i> , 2008)
Triple-negative breast carcinoma	MDA-231(GFP+)	Systemic delivery of DCN protein core	Decreased growth and enhanced apoptosis	(Buraschi <i>et al.</i> , 2012)
Colorectal carcinoma	HCT116	Ectopic expression	Decreased growth and enhanced apoptosis	(Bi <i>et al.</i> , 2012)
Bladder cancer	RT4, T24	Ad-DCN	Decreased proliferation	(Sainio <i>et al.</i> , 2013)
Cholangiocarcinoma	QBC939	Ectopic expression	Decreased growth and enhanced apoptosis	(Yu <i>et al.</i> , 2014)
Colorectal adenocarcinoma, colonic carcinoma, and colorectal carcinoma	CO115, HCT-116, DLD-1, HT-29, Vaco-5, LS180, SW620, RKO	Ad-DCN	Decrease in colony forming capability	(Nyman <i>et al.</i> , 2015)
Bone metastases of breast carcinoma	MDA-MB-231	Ad-DCN and oncolytic Ad-DCN	Inhibition of bone metastases progression	(Yang <i>et al.</i> , 2015)
Bone metastases of prostate cancer	PC-3, DU-145	Oncolytic Ad-DCN	Inhibition of bone metastases	(Xu <i>et al.</i> , 2015)
Lung carcinoma	A549	Oncolytic Ad-DCN with single shRNA specific to Met	Increased tumour cell death	(Yoon <i>et al.</i> , 2016)
Colorectal adenocarcinoma	SW480, SW620, CT26 (murine)	Ad-DCN and oncolytic Ad-DCN with GM-CSF	Decreased growth	(Liu <i>et al.</i> , 2017)
Metaplastic breast carcinoma	Tissue samples	Ad-DCN	Decreased proliferation and increased apoptosis	(Boström <i>et al.</i> , 2017)
Pancreatic cancer	MIA PaCa-2	Oncolytic Ad-DCN	Decreased growth and increased apoptosis	(Li <i>et al.</i> , 2018)
Breast carcinoma	4 T1 (murine)	Ad-DCN	Decreased progression	(Dawoody Nejad <i>et al.</i> , 2017)
Breast carcinoma	4 T1 (murine)	Oncolytic Ad-DCN with interleukin 12	Increase in antitumor immune function	(Oh <i>et al.</i> , 2017)

DCN, decorin; GM-CSF, granulocyte macrophage colony stimulating factor; shRNA, short hairpin RNA.

of Met, β -catenin and VEGFA production (Yang *et al.*, 2015). Furthermore, both Ad-decorin and oncolytic Ad-decorin were demonstrated to inhibit bone destruction and reduce tumour burden in breast carcinoma (Yang *et al.*, 2015). Bone destruction is the result of the interplay between the cancer cells and the bone micro-environment resulting in release of various cytokines and osteolytic factors. Thus, the potency of decorin to prevent bone metastasis emphasizes its capability to target both the cancer cells and their tumour-boned micro-environment (Yang *et al.*, 2015). Identically, inhibition of

the Met- β -catenin-VEGFA axis by oncolytic adenoviral decorin has been achieved in a mouse model of prostate cancer (Xu *et al.*, 2015). In this particular animal model, which used nude mice with established bone metastases, the systemic delivery of decorin bearing adenovirus resulted in increased overall survival of the mice and significant reduction in the tumour burden. Additionally, a marked inhibition of cancer cachexia, a significant reduction in osteoclast number, osteocalcin levels and hypercalcaemia were detected (Xu *et al.*, 2015).

In colon carcinoma, the oncosuppressive action of ectopic decorin expression was shown to be mediated *via* induced arrest of cancer cells in G1 phase of cell cycle (Santra *et al.*, 1997). More precisely, the arrested cell cycle is associated with the induction of p21^{WAF-1}, its subsequent translocation into the nuclei, finally resulting in G1 phase arrest of the cells (Santra *et al.*, 1997). Regarding colon cancer, the genetic deficiency of decorin has been identified to cause intestinal tumour formation in decorin knockout mice (*DCN*^{-/-}) *via* disruption of intestinal cell maturation (Bi *et al.*, 2008). These mice exhibit decreased intestinal cell maturation and increased cell proliferation. This was shown to be the result of the down-regulation of several factors, including p21^{WAF-1} and p27^{Kip-1}, and E-cadherin, along with the up-regulation of the β -catenin signalling pathway (Bi *et al.*, 2008). Thereafter, experiments using the same mouse model, together with colon cancer cells transfected with decorin overexpressing plasmids, revealed that the oncosuppressive action of ectopic decorin was associated with the increased stability of E-cadherin protein (Bi *et al.*, 2012). Furthermore, an exogenous administration of decorin protein to cholangiocarcinoma cells significantly increased the expression of E-cadherin (Yu *et al.*, 2014). E-cadherin is known for its regulatory action among other things, on epithelial-mesenchymal transition, cell-cell adhesion and cancer cell metastasis. Other decorin-induced oncosuppressive regulatory pathways include the promotion of **caspase-8** activity in lung carcinoma (Tralhão *et al.*, 2003). Caspase-8 is able to both induce cell death directly by activating effector caspases and by initiating other apoptotic cascades. In our own studies, we have achieved oncosuppression in different carcinoma cells using recombinant human decorin cDNA-based adenoviral vector (Boström *et al.*, 2013; Sainio *et al.*, 2013; Nyman *et al.*, 2015; Boström *et al.*, 2017). Although the precise mechanisms behind the observed oncosuppression are not yet known, our preliminary results indicate among other things induction and involvement of anti-tumorigenic microRNAs.

No detectable decorin-induced toxicity has been found in any of the preclinical studies described above. Currently, modified adenovirus-based hybrid vectors represent one of the most common tools to deliver genes into cells and organisms. As in Table 1, most preclinical studies using adenovirus-based decorin delivery have focused on replication-defective Ad-DCN vectors, although some replication-competent, so-called oncolytic adenoviral vectors, have also been tested. Compared with non-replicative adenoviral vectors, the use of oncolytic Ad-therapy may result in general tissue cytotoxicity if it is not targeted to tumour cells. This is based on the nature of oncolytic viruses, as they replicate within cells and execute the lytic life cycle of viruses, resulting in cellular death. However, the use of oncolytic viruses can improve penetration and viral spread in the cancer tissue due to ECM disruption (Li *et al.*, 2018). Tissue penetration can be problematic specifically in cancers like pancreatic cancer, where the cancer tissue is often surrounded by a pronounced accumulation of ECM macromolecules (Li *et al.*, 2018). With the aim of producing cancer cell-specific virus replication and enhanced antitumor effects, oncolytic adenoviral vectors and decorin have been tested in various combinations with other genes (Yoon *et al.*, 2016; Oh *et al.*, 2017; Li *et al.*, 2018). For

example, in an orthotopic breast cancer model, using oncolytic adenoviral decorin-IL-12-vector resulted in enhanced anti-tumorigenic immune activity in weakly immunogenic BALB/c mice (Oh *et al.*, 2017). This was achieved with significantly increased expression of TNF- α , CCL2 and interferon γ with simultaneous decorin-mediated attenuation of TGF- β activity (Oh *et al.*, 2017). Despite these so far promising results, no adenoviral decorin-based therapy for cancer has been established. Interestingly, a decorin-based angiogenic blood vessel targeting peptide has been developed for suppression of fibrotic scars during wound healing (Järvinen and Prince, 2015). This so-called CAR-decorin utilizes the capability of decorin to bind and inhibit the activity of TGF- β , thus reducing tissue fibrosis and enabling tissue regeneration (Järvinen and Prince, 2015). Nevertheless, this therapy has not yet advanced to clinical trials as an anti-scarring agent.

Decorin and tumoriangiogenesis

Angiogenesis, the development of new blood vessel from pre-existing vessels, is a requirement for tumour progression after cancer has reached a certain size. It is governed by complex regulatory pathways, consisting of both pro- and anti-angiogenic factors. VEGF and its receptors represent an essential example of different molecules regulating the signalling cascades in physiological and pathological angiogenesis (Järveläinen *et al.*, 2015). During angiogenesis, the role of decorin has been shown to be context-dependent; in other words, it can exhibit either a pro-angiogenic or an anti-angiogenic activity. In the context of tumorigenesis, the role of decorin is anti-angiogenic. Studies have demonstrated that also peptides derived from decorin possess anti-angiogenic properties, similar to the mother molecule (Sulochana *et al.*, 2005; El Shafey *et al.*, 2016). For instance, a 26-residue LRR-5 peptide was demonstrated to prevent angiogenesis *via* any different signalling pathways, including inhibition of VEGF-activated migration of endothelial cells, and cell attachment to fibronectin (Sulochana *et al.*, 2005). Such inhibition was shown to be mediated *via* a signalling pathway involving **PI3K/Akt** and **NO synthase**, resulting in reduced production of **NO** in endothelial cells (Fan *et al.*, 2008). Short decorin-derived peptides (El Shafey *et al.*, 2016) and the decorin mimic DS-SILY (Scott *et al.*, 2013) also exhibit anti-angiogenic properties *via* inhibition of the myostatin/Smad signalling pathway and sequestration of **PDGF** respectively. Nevertheless, the true anti-angiogenic effects of these decorin-derived peptides and the decorin mimic during angiogenesis are still unclear.

Conclusion and future directions

Decorin's capability to interact with a variety of molecules including growth factors and their receptors, other ECM macromolecules and cytokines enables decorin to act as a potent oncosuppressive ECM molecule. Indeed, decorin is crucially involved in various signalling pathways regulating tumorigenesis, particularly inhibiting growth, metastasis and angiogenesis of tumours. Recently, it has been demonstrated that decorin is also able to induce autophagy and mitophagy. In light of the promising preclinical studies that have employed decorin or decorin expression to treat cancer, it is rational to further extend this field of research. However,

there are still several obstacles including the targeting and successful penetration of the decorin-based therapy to different malignancies that need to be resolved before the true therapeutic potential of decorin is realised.

Nomenclature of molecular targets

Key protein targets and ligands in this article are hyperlinked to corresponding entries in <http://www.guidetopharmacology.org>, the common portal for data from the IUPHAR/BPS Guide to PHARMACOLOGY (Harding *et al.*, 2018), and are permanently archived in the Concise Guide to PHARMACOLOGY 2017/18 (Alexander *et al.*, 2017a,b,c).

Acknowledgements

We are grateful to the funding from State Research Funding of the Satakunta Central Hospital and Cancer Society of Southwestern Finland.

Conflict of interest

The authors declare no conflicts of interest.

References

- Adam M, Urbanski HF, Garyfallou VT, Welsch U, Kohn FM, Ullrich Schwarzer J *et al.* (2012). High levels of the extracellular matrix proteoglycan decorin are associated with inhibition of testicular function. *Int J Androl* 35: 550–561.
- Afratis NA, Bouris P, Skandalis SS, Multhaupt HA, Couchman JR, Theocharis AD *et al.* (2017). IGF-1R cooperates with ERalpha to inhibit breast cancer cell aggressiveness by regulating the expression and localisation of ECM molecules. *Sci Rep* 7: 40138.
- Alexander SPH, Fabbro D, Kelly E, Marrion NV, Peters JA, Faccenda E *et al.* (2017a). The Concise Guide to PHARMACOLOGY 2017/18: Enzymes. *Br J Pharmacol* 174: S272–S359.
- Alexander SPH, Fabbro D, Kelly E, Marrion NV, Peters JA, Faccenda E *et al.* (2017b). The Concise Guide to PHARMACOLOGY 2017/18: Catalytic receptors. *Br J Pharmacol* 174: S225–S271.
- Alexander SPH, Cidrowski JA, Kelly E, Marrion NV, Peters JA, Faccenda E *et al.* (2017c). The Concise Guide to PHARMACOLOGY 2017/18: Nuclear hormone receptors. *Br J Pharmacol* 174: S208–S224.
- Bi X, Pohl NM, Qian Z, Yang GR, Gou Y, Guzman G *et al.* (2012). Decorin-mediated inhibition of colorectal cancer growth and migration is associated with E-cadherin *in vitro* and in mice. *Carcinogenesis* 33: 326–330.
- Bi X, Tong C, Dockendorff A, Bancroft L, Gallagher L, Guzman G *et al.* (2008). Genetic deficiency of decorin causes intestinal tumor formation through disruption of intestinal cell maturation. *Carcinogenesis* 29: 1435–1440.
- Bi XL, Yang W (2013). Biological functions of decorin in cancer. *Chin J Cancer* 32: 266–269.
- Boström P, Sainio A, Eigélienė N, Jokilampi A, Elenius K, Koskivuo I *et al.* (2017). Human metaplastic breast carcinoma and decorin. *Cancer Microenviron* 10: 39–48.
- Boström P, Sainio A, Kakko T, Savontaus M, Söderström M, Järveläinen H (2013). Localization of decorin gene expression in normal human breast tissue and in benign and malignant tumors of the human breast. *Histochem Cell Biol* 139: 161–171.
- Buraschi S, Neill T, Iozzo RV (2017). Decorin is a devouring proteoglycan: remodeling of intracellular catabolism via autophagy and mitophagy. *Matrix Biol*. pii: S0945-053X(17)30326-8.
- Buraschi S, Neill T, Owens RT, Iniguez LA, Purkins G, Vadigepalli R *et al.* (2012). Decorin protein core affects the global gene expression profile of the tumor microenvironment in a triple-negative orthotopic breast carcinoma xenograft model. *PLoS One* 7: e45559.
- Danielson KG, Baribault H, Holmes DF, Graham H, Kadler KE, Iozzo RV (1997). Targeted disruption of decorin leads to abnormal collagen fibril morphology and skin fragility. *J Cell Biol* 136: 729–743.
- Dawoody Nejad L, Biglari A, Anness T, Ribatti D (2017). Recombinant fibromodulin and decorin effects on NF-kappaB and TGFbeta1 in the 4T1 breast cancer cell line. *Oncol Lett* 13: 4475–4480.
- El Shafey N, Guesnon M, Simon F, Deprez E, Cosette J, Stockholm D *et al.* (2016). Inhibition of the myostatin/Smad signaling pathway by short decorin-derived peptides. *Exp Cell Res* 341: 187–195.
- Fan H, Sulochana KN, Chong YS, Ge R (2008). Decorin derived antiangiogenic peptide LRR5 inhibits endothelial cell migration by interfering with VEGF-stimulated NO release. *Int J Biochem Cell Biol* 40: 2120–2128.
- Fetting JL, Guay JA, Karolak MJ, Iozzo RV, Adams DC, Maridas DE *et al.* (2014). FOXD1 promotes nephron progenitor differentiation by repressing decorin in the embryonic kidney. *Development* 141: 17–27.
- Frey H, Schroeder N, Manon-Jensen T, Iozzo RV, Schaefer L (2013). Biological interplay between proteoglycans and their innate immune receptors in inflammation. *FEBS J* 280: 2165–2179.
- Goldoni S, Seidler DG, Heath J, Fassan M, Baffa R, Thakur ML *et al.* (2008). An antimetastatic role for decorin in breast cancer. *Am J Pathol* 173: 844–855.
- Goyal A, Neill T, Owens RT, Schaefer L, Iozzo RV (2014). Decorin activates AMPK, an energy sensor kinase, to induce autophagy in endothelial cells. *Matrix Biol* 34: 46–54.
- Gubbiotti MA, Vallet SD, Ricard-Blum S, Iozzo RV (2016). Decorin interacting network: a comprehensive analysis of decorin-binding partners and their versatile functions. *Matrix Biol* 55: 7–21.
- Harding SD, Sharman JL, Faccenda E, Southan C, Pawson AJ, Ireland S *et al.* (2018). The IUPHAR/BPS Guide to PHARMACOLOGY in 2018: updates and expansion to encompass the new guide to IMMUNOPHARMACOLOGY. *Nucl Acids Res* 46: D1091–D1106.
- Iozzo RV, Chakrani F, Perrotti D, McQuillan DJ, Skorski T, Calabretta B *et al.* (1999). Cooperative action of germ-line mutations in decorin and p53 accelerates lymphoma tumorigenesis. *Proc Natl Acad Sci U S A* 96: 3092–3097.
- Järveläinen H, Sainio A, Wight TN (2015). Pivotal role for decorin in angiogenesis. *Matrix Biol* 43: 15–26.
- Järvinen TA, Prince S (2015). Decorin: a growth factor antagonist for tumor growth inhibition. *Biomed Res Int* 2015: 654765.
- Kanehisa M, Furumichi M, Tanabe M, Sato Y, Morishima K (2017). KEGG: new perspectives on genomes, pathways, diseases and drugs. *Nucleic Acids Res* 45: D353–D361.

- Königer J, Giese NA, Bartel M, di Mola FF, Berberat PO, di Sebastiano P *et al.* (2006). The ECM proteoglycan decorin links desmoplasia and inflammation in chronic pancreatitis. *J Clin Pathol* 59: 21–27.
- Königer J, Giese NA, di Mola FF, Berberat P, Giese T, Esposito I *et al.* (2004). Overexpressed decorin in pancreatic cancer: potential tumor growth inhibition and attenuation of chemotherapeutic action. *Clin Cancer Res* 10: 4776–4783.
- Li Y, Hong J, Oh JE, Yoon AR, Yun CO (2018). Potent antitumor effect of tumor microenvironment-targeted oncolytic adenovirus against desmoplastic pancreatic cancer. *Int J Cancer* 142: 392–413.
- Li Y, Liu Y, Xia W, Lei D, Voorhees JJ, Fisher GJ (2013). Age-dependent alterations of decorin glycosaminoglycans in human skin. *Sci Rep* 3: 2422.
- Liu Z, Yang Y, Zhang X, Wang H, Xu W, Wang H *et al.* (2017). An oncolytic adenovirus encoding decorin and GM-CSF inhibits tumor growth in a colorectal tumor model by targeting pro-tumorigenic signals and via immune-activation. *Hum Gene Ther* 28: 667–680.
- Merline R, Moreth K, Beckmann J, Nastase MV, Zeng-Brouwers J, Tralhao JG *et al.* (2011). Signaling by the matrix proteoglycan decorin controls inflammation and cancer through PDCD4 and MicroRNA-21. *Sci Signal* 4: ra75.
- Minor KH, Bournat JC, Toscano N, Giger RJ, Davies SJ (2011). Decorin, erythroblastic leukaemia viral oncogene homologue B4 and signal transducer and activator of transcription 3 regulation of semaphorin 3A in central nervous system scar tissue. *Brain* 134: 1140–1155.
- Morrione A, Neill T, Iozzo RV (2013). Dichotomy of decorin activity on the insulin-like growth factor-I system. *FEBS J* 280: 2138–2149.
- Nash MA, Loercher AE, Freedman RS (1999). *In vitro* growth inhibition of ovarian cancer cells by decorin: synergism of action between decorin and carboplatin. *Cancer Res* 59: 6192–6196.
- Nastase MV, Janicova A, Roedig H, Hsieh LT, Wygrecka M, Schaefer L (2017). Small leucine-rich proteoglycans in renal inflammation: two sides of the coin. *J Histochem Cytochem* 22155417738752, <https://doi.org/10.1369/0022155417738752>
- Neill T, Schaefer L, Iozzo RV (2016). Decorin as a multivalent therapeutic agent against cancer. *Adv Drug Deliv Rev* 97: 174–185.
- Neill T, Schaefer L, Iozzo RV (2015a). Decoding the matrix: instructive roles of proteoglycan receptors. *Biochemistry* 54: 4583–4598.
- Neill T, Schaefer L, Iozzo RV (2015b). Oncosuppressive functions of decorin. *Mol Cell Oncol* 2: e975645.
- Nyman MC, Sainio AO, Pennanen MM, Lund RJ, Vuorikoski S, Sundström JT *et al.* (2015). Decorin in human colon cancer: localization *in vivo* and effect on cancer cell behavior *in vitro*. *J Histochem Cytochem* 63: 710–720.
- Oh E, Choi IK, Hong J, Yun CO (2017). Oncolytic adenovirus coexpressing interleukin-12 and decorin overcomes Treg-mediated immunosuppression inducing potent antitumor effects in a weakly immunogenic tumor model. *Oncotarget* 8: 4730–4746.
- Reed CC, Waterhouse A, Kirby S, Kay P, Owens RT, McQuillan DJ *et al.* (2005). Decorin prevents metastatic spreading of breast cancer. *Oncogene* 24: 1104–1110.
- Sainio A, Nyman M, Lund R, Vuorikoski S, Boström P, Laato M *et al.* (2013). Lack of decorin expression by human bladder cancer cells offers new tools in the therapy of urothelial malignancies. *PLoS One* 8: e76190.
- Santra M, Mann DM, Mercer EW, Skorski T, Calabretta B, Iozzo RV (1997). Ectopic expression of decorin protein core causes a generalized growth suppression in neoplastic cells of various histogenetic origin and requires endogenous p21, an inhibitor of cyclin-dependent kinases. *J Clin Invest* 100: 149–157.
- Schaefer L, Tredup C, Gubbiotti MA, Iozzo RV (2017). Proteoglycan neofunctions: regulation of inflammation and autophagy in cancer biology. *FEBS J* 284: 10–26.
- Scott RA, Paderi JE, Sturek M, Panitch A (2013). Decorin mimic inhibits vascular smooth muscle proliferation and migration. *PLoS One* 8: e82456.
- Seidler DG, Dreier R (2008). Decorin and its galactosaminoglycan chain: extracellular regulator of cellular function? *IUBMB Life* 60: 729–733.
- Seidler DG, Goldoni S, Agnew C, Cardi C, Thakur ML, Owens RT *et al.* (2006). Decorin protein core inhibits *in vivo* cancer growth and metabolism by hindering epidermal growth factor receptor function and triggering apoptosis via caspase-3 activation. *J Biol Chem* 281: 26408–26418.
- Skandalis SS, Kleatsas D, Kyriakopoulou D, Stavropoulos M, Theocharis DA (2006). The greatly increased amounts of accumulated versican and decorin with specific post-translational modifications may be closely associated with the malignant phenotype of pancreatic cancer. *Biochim Biophys Acta* 1760: 1217–1225.
- Sulochana KN, Fan H, Jois S, Subramanian V, Sun F, Kini RM *et al.* (2005). Peptides derived from human decorin leucine-rich repeat 5 inhibit angiogenesis. *J Biol Chem* 280: 27935–27948.
- Tannock LR (2014). Proteoglycan-LDL interactions: a novel therapeutic target? *Atherosclerosis* 233: 232–233.
- Theocharis AD (2002). Human colon adenocarcinoma is associated with specific post-translational modifications of versican and decorin. *Biochim Biophys Acta* 1588: 165–172.
- Theocharis AD, Karamanos NK (2017). Proteoglycans remodeling in cancer: underlying molecular mechanisms. *Matrix Biol.* <https://doi.org/10.1016/j.matbio.2017.10.008>
- Theocharis AD, Vynios DH, Papageorgakopoulou N, Skandalis SS, Theocharis DA (2003). Altered content composition and structure of glycosaminoglycans and proteoglycans in gastric carcinoma. *Int J Biochem Cell Biol* 35: 376–390.
- Torres A, Gubbiotti MA, Iozzo RV (2017). Decorin-inducible Peg3 evokes beclin 1-mediated autophagy and thrombospondin 1-mediated angiostasis. *J Biol Chem* 292: 5055–5069.
- Tralhão JG, Schaefer L, Micegova M, Evaristo C, Schönherr E, Kayal S *et al.* (2003). *In vivo* selective and distant killing of cancer cells using adenovirus-mediated decorin gene transfer. *FASEB J* 17: 464–466.
- Xaus J, Comalada M, Cardó M, Valledor AF, Celada A (2001). Decorin inhibits macrophage colony-stimulating factor proliferation of macrophages and enhances cell survival through induction of p27(Kip1) and p21(Waf1). *Blood* 98: 2124–2133.
- Xu W, Neill T, Yang Y, Hu Z, Cleveland E, Wu Y *et al.* (2015). The systemic delivery of an oncolytic adenovirus expressing decorin inhibits bone metastasis in a mouse model of human prostate cancer. *Gene Ther* 22: 247–256.
- Yamaguchi Y, Mann DM, Ruoslahti E (1990). Negative regulation of transforming growth factor-beta by the proteoglycan decorin. *Nature* 346: 281–284.

Yang Y, Xu W, Neill T, Hu Z, Wang CH, Xiao X *et al.* (2015). Systemic delivery of an oncolytic adenovirus expressing decorin for the treatment of breast cancer bone metastases. *Hum Gene Ther* 26: 813–825.

Yoon AR, Kasala D, Li Y, Hong J, Lee W, Jung SJ *et al.* (2016). Antitumor effect and safety profile of systemically delivered oncolytic

adenovirus complexed with EGFR-targeted PAMAM-based dendrimer in orthotopic lung tumor model. *J Control Release* 231: 2–16.

Yu X, Zou Y, Li Q, Mao Y, Zhu H, Huang G *et al.* (2014). Decorin-mediated inhibition of cholangiocarcinoma cell growth and migration and promotion of apoptosis are associated with E-cadherin *in vitro*. *Tumour Biol* 35: 3103–3112.